

**MGB 770 SL
DIN VERSION**

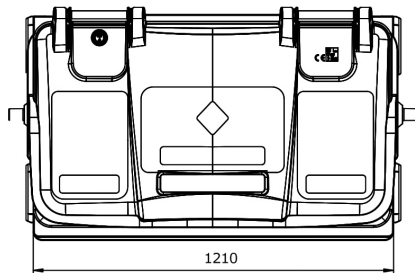
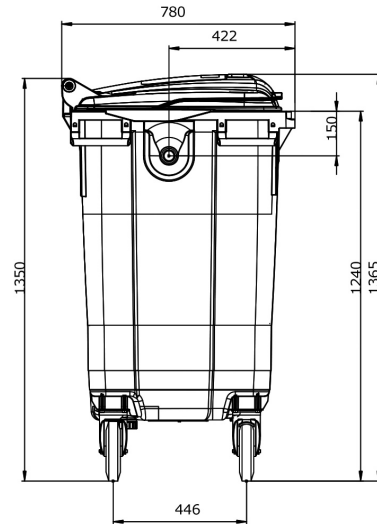
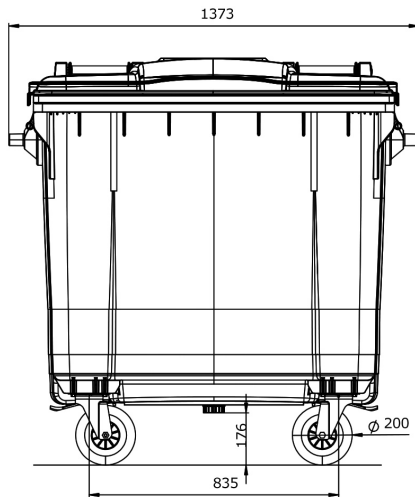

TECHNICAL DATA

Volume (L):	770
Weight (kg):	approx. 43
Nominal load (kg):	max. 360
Material:	HDPE, UV-stabilized
Wheels:	4 rubber wheels Ø 200 mm 2 with wheel stop
Lid / Body:	4 hinge pins Lid with liphandle
Trunnions:	Left and right identical
Certification:	EN 840; RAL GZ 951/1

OPTIONS

- Pad- / Triangular- / Gravity lock
- Recycling inserts for glass, paper and packaging
- Individual identification
- Noise reduction
- Foot-operated lid opening
- Direction lock for castors
- Heavy load wheels / alternative wheels Ø 160 mm
- Central brake system (CBS)
- Lateral handle (incl. CBS)
- Towing equipment / Fork lift pockets

The products do not contain any substances on the SVHC list of the European Chemicals Agency (ECHA).